



ISO-UNI FITTINGS
PVC-C

TemperFIP100® solvent weld fittings, metric series

FITTINGS ISO-UNI

Series of fittings designed for conveying fluids under pressure with a cold chemical weld jointing system (solvent welding) using a suitable solvent cement (TemperGLUE WELD-ON) and cleaner-primer.

SOLVENT WELD FITTINGS, METRIC SERIES

Technical specifications	
Size range	d 16 ÷ 225 (mm)
Nominal pressure	PN 16 with water at 20° C
Temperature range	0 °C ÷ 100 °C
Coupling standards	Solvent welding: EN ISO 15493 Can be coupled to pipes according to EN ISO 15493 Flanging system: ISO 7005-1, EN ISO 15493, DIN 2501, ANSI B.16.5 cl. 150
Reference standards	Construction criteria: EN ISO 15493 Test methods and requirements: EN ISO 15493 Installation criteria: DVS 2204, DVS 2221, UNI 11242
Fitting material	PVC-C
Seal material	EPDM, FPM

TECHNICAL DATA

REGRESSION CURVE FOR PVC-C FITTINGS

Regression coefficients in accordance with standard EN ISO 15493 for minimum MRS = 20 N/mm² (MPa).

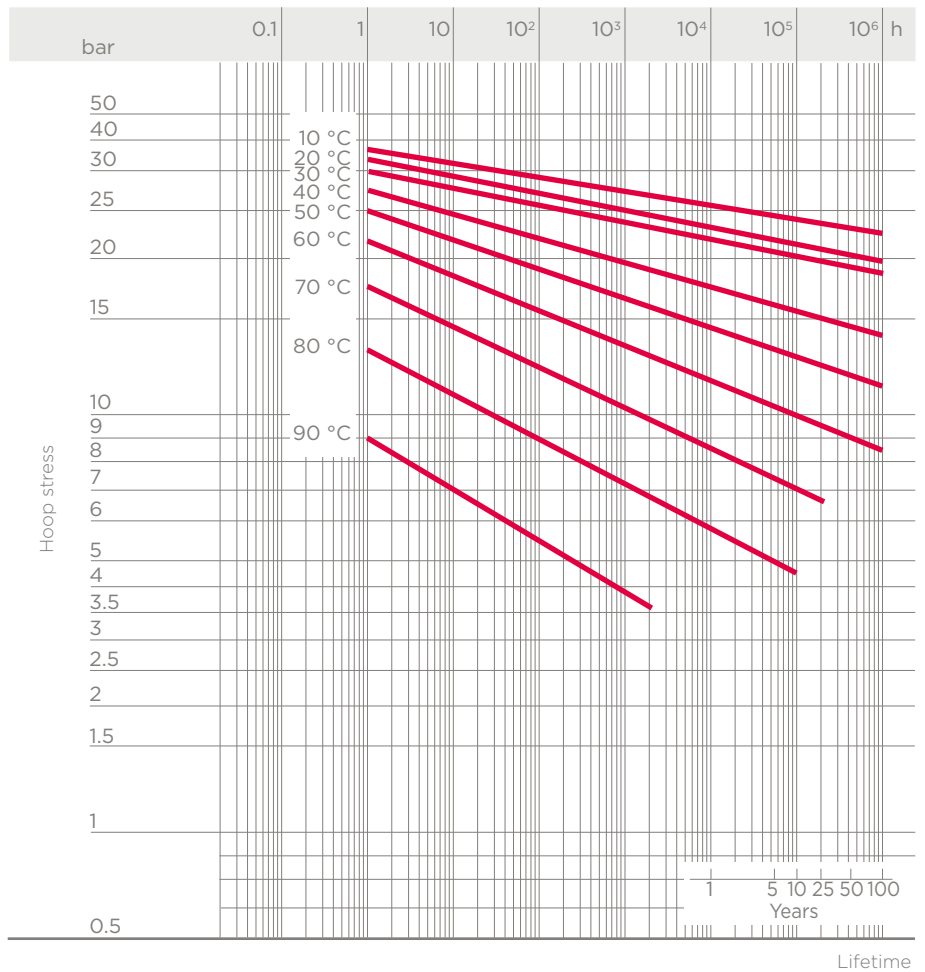

PRESSURE VARIATION ACCORDING TO TEMPERATURE

For water and non-hazardous fluids for which the material is classified as CHEMICALLY RESISTANT (life expectancy 25 years). In other cases, a reduction of the nominal pressure PN is required.

Note

When using PVC-C at working temperatures higher than 90°, it is advisable to first contact the service centre.

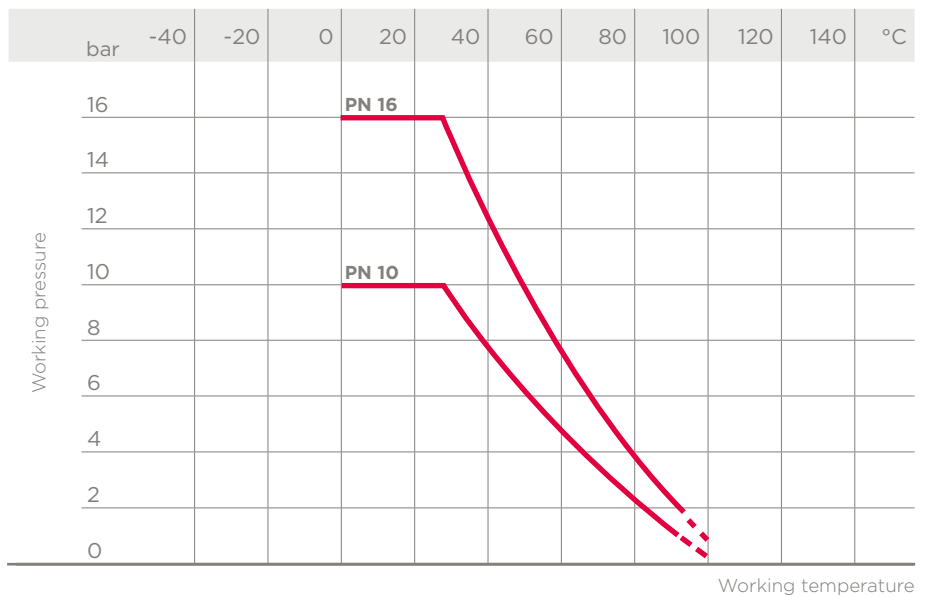

The information in this leaflet is provided in good faith. No liability will be accepted concerning technical data that is not directly covered by recognised international standards. FIP reserves the right to carry out any modification. Products must be installed and maintained by qualified personnel.

DIMENSIONS

Fig. A

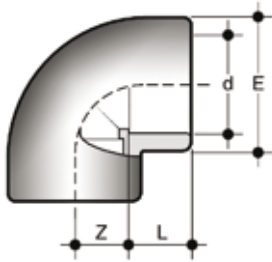

GIC

90° elbow with solvent weld sockets (fig. A)

d	PN	E	L	Z	g	Code
16	16	22	14	9	12	GIC016
20	16	27	16	11.5	20	GIC020
25	16	33	19	14	34	GIC025
32	16	41	22	16.5	56	GIC032
40	16	50	26	22.5	95	GIC040
50	16	61	31	27	155	GIC050
63	16	76	38	33.5	283	GIC063
75	16	91	44	40.3	490	GIC075
90	16	107	51	48	745	GIC090
110	16	130	61	60	1265	GIC110
160	16	193	86	88	4500	GIC160

Fig. B

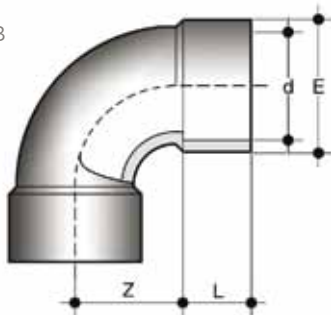

GIC

90° elbow with solvent weld sockets (fig. B)

d	PN	E	L	Z	g	Code
225	10	258	119	172	9270	GIC225

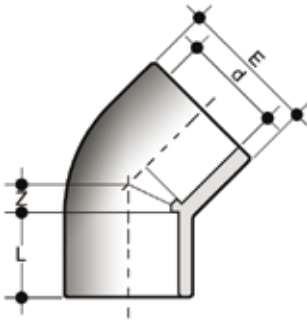

HIC

45° elbow with solvent weld sockets

d	PN	E	L	Z	g	Code
20	16	28	16	5.5	20	HIC020
25	16	34	19	6	32	HIC025
32	16	42.5	22	7	58	HIC032
40	16	52	26	10.5	101	HIC040
50	16	64	31	11.7	175	HIC050
63	16	80	38	14	305	HIC063
75	16	90	44	17	344	HIC075
90	16	107	51	21.5	587	HIC090
110	16	130	61	26	1007	HIC110
160	16	192	86	38	3255	HIC160
225	10	260	121	55	7150	HIC225

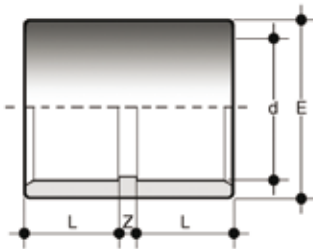

MIC

Solvent weld double socket

d	PN	E	L	Z	g	Code
16	16	22	14	3	9	MIC016
20	16	27	16	3	11	MIC020
25	16	33	19	3	21	MIC025
32	16	41	22	3	31	MIC032
40	16	50	26	3	58	MIC040
50	16	61	31	3	90	MIC050
63	16	75	38	3	160	MIC063
75	16	89	44	3	260	MIC075
90	16	108	51	5	465	MIC090
110	16	130	61	9	750	MIC110
160	16	186	86	9	1820	MIC160
225	10	260	119	11	5360	MIC225

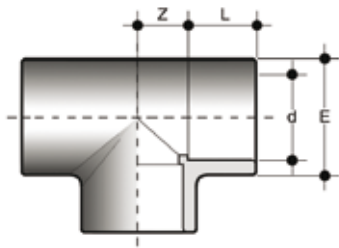

TIC
90° Tee with solvent weld sockets

d	PN	E	L	Z	g	Code
16	16	22	14	9	15	TIC016
20	16	27	16	11	25	TIC020
25	16	33	19	14	45	TIC025
32	16	41	22	17.5	75	TIC032
40	16	50	26	22	125	TIC040
50	16	61	31	27	195	TIC050
63	16	76	38	33.5	394	TIC063
75	16	91	44	38.5	667	TIC075
90	16	109	51	48	1075	TIC090
110	16	133	61	61	1920	TIC110
160	16	192	86	89	5730	TIC160
225	10	258	119	114	10800	TIC225

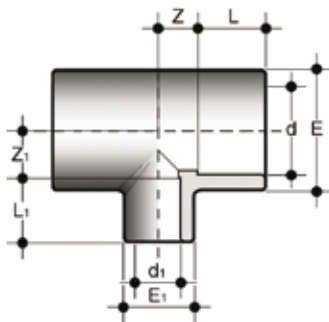

TRIC
90° reducing Tee with reduced branch and solvent weld sockets

d x d ₁	PN	E	E ₁	L	L ₁	Z	Z ₁	g	Code
25 x 20	16	33	28	19	16	14	14	41	TRIC025020
32 x 20	16	41	28	22	16	17.5	17.5	66	TRIC032020
32 x 25	16	41	34	22	19	17.5	17.5	72	TRIC032025
40 x 20	16	50	29	26	16	22	22	111	TRIC040020
40 x 25	16	50	34	26	19	22	22	111	TRIC040025
50 x 25	16	61	35	31	19	27	27	176	TRIC050025
50 x 32	16	61	42	31	22	27	27	182	TRIC050032
63 x 25	16	76	36	38	19	33.5	33.5	320	TRIC063025
63 x 32	16	76	43	38	22	33.5	33.5	325	TRIC063032
75 x 25	16	91	33	44	16	40.5	39	470	TRIC075025
90 x 25	16	109	33	51	16	48.5	46	773	TRIC090025
110 x 25	16	133	33	61	16	61	56	1170	TRIC110025

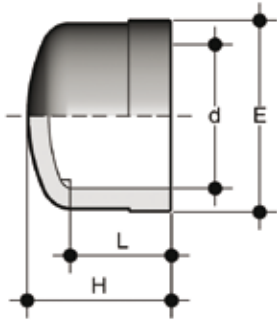

CIC

End cap with solvent weld socket

d	PN	E	H	L	g	Code
20	16	28	23	16	9	CIC020
25	16	34	27	19	16	CIC025
32	16	41	31	22	25	CIC032
40	16	51	36	26	42	CIC040
50	16	62	43	31	64	CIC050
63	16	77	51	38	115	CIC063
75	16	91	59	44	205	CIC075
90	16	110	69	51	260	CIC090
110	16	132	83	61	555	CIC110

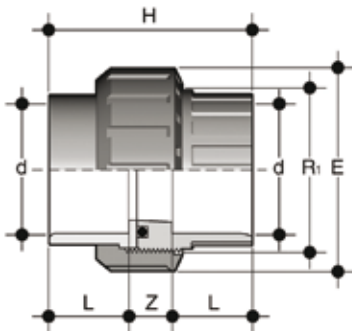

BIC

Union with solvent weld socket, with O-Ring in EPM or FPM

d	R ₁	DN	PN	E	H	L	Z	g	EPDM Code	FPM Code
16	3/4	10	16	33	41	14	13	23	BIC016E	BIC016F
20	1	15	16	41	45	16	13	39	BIC020E	BIC020F
25	1"1/4	20	16	50	51	19	13	68	BIC025E	BIC025F
32	1"1/2	25	16	58	57	22	13	94	BIC032E	BIC032F
40	2	32	16	72	67	26	15	163	BIC040E	BIC040F
50	2"1/4	40	16	79	79	31	17	190	BIC050E	BIC050F
63	2"3/4	50	16	98	98	38	22	355	BIC063E	BIC063F

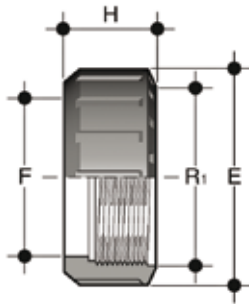

EFC

Union nut with BSP thread for union types BIC, BIFC, BFC, BLC, BIRC, BIFOC, BIROC, BIFXC, BIRXC.

R ₁	d BIC	PN	E	F	H	g	Code
3/4"	16	16	33	22	21	9	EFC034
1"	20	16	41	28	22	13	EFC100
1"1/4	25	16	50	36	25	22	EFC114
1"1/2	32	16	58	42	27	30	EFC112
2"	40	16	72	53	30	50	EFC200
2"1/4	50	16	79	59	34	68	EFC214
2"3/4	63	16	98	74	38	120	EFC234

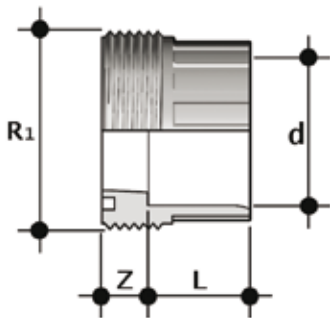

F/BIC

Union bush for solvent welding, metric series

d	R ₁	PN	L	Z	g	Code
16	3/4"	16	14	10	9	FBIC016
20	1"	16	16	10	13	FBIC020
25	1"1/4	16	19	10	25	FBIC025
32	1"1/2	16	22	10	31	FBIC032
40	2"	16	26	12	58	FBIC040
50	2"1/4	16	31	14	63	FBIC050
63	2"3/4	16	38	19	119	FBIC063

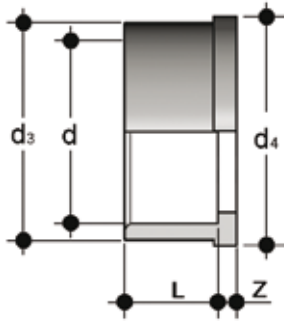

Q/BIC

Union end for solvent welding, metric series

d	PN	d ₃	d ₄	L	Z	g	Code
16	16	22	24	14	3	5	QBIC016
20	16	27.5	30.1	16	3	10	QBIC020
25	16	36	38.8	19	3	16	QBIC025
32	16	41.5	44.7	22	3	23	QBIC032
40	16	53	56.5	26	3	40	QBIC040
50	16	59	62.6	31	3	44	QBIC050
63	16	74	78.4	38	3	82	QBIC063

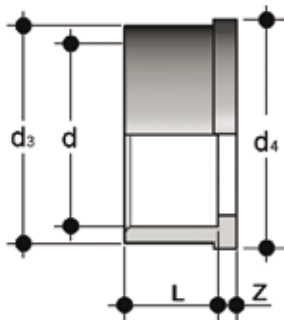

Q/BAC

Union end for solvent welding, ASTM series

d	PN	d ₃	d ₄	L	Z	g	Code
1/2"	16	27.5	30.1	22.7	3.5	17	QBAC012
3/4"	16	36	38.8	25.9	3.7	25	QBAC034
1"	16	41.5	44.7	29.2	3	36	QBAC100
1"1/4	16	53	56.5	32	5	63	QBAC114
1"1/2	16	59	62.6	35	5	86	QBAC112
2"	16	74	78.4	38.5	5.5	143	QBAC200

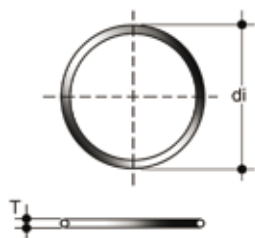

O-Ring

O-Ring for union types BIC, BIFC, BIFOC, BIFXC, BIRXC

Union d	C	di	T	EPDM Code	FPM Code
16	3062	15.54	2.62	OR3062E	OR3062F
20	4081	20.22	3.53	OR4081E	OR4081F
25	4112	28.17	3.53	OR4112E	OR4112F
32	4131	32.93	3.53	OR4131E	OR4131F
40	6162	40.65	5.34	OR6162E	OR6162F
50	6187	47	5.34	OR6187E	OR6187F
63	6237	59.69	5.34	OR6237E	OR6237F
75	6300	75.57	5.34	OR6300E	OR6300F
90	6362	91.45	5.34	OR6362E	OR6362F
110	6450	113.67	5.34	OR6450E	OR6450F

Fig. A

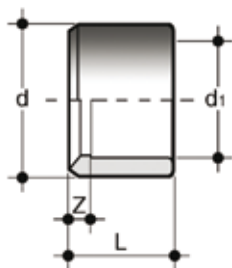

DIC

Reducing bush with solvent weld spigot (d) and solvent weld socket (di reduced) (fig. A)

d x di	PN	L	Z	g	Code
20 x 16	16	16	2	3	DIC020016
25 x 20	16	19	3	6	DIC025020
32 x 20	16	22	6	16	DIC032020
32 x 25	16	22	3	11	DIC032025
40 x 32	16	26	4	18	DIC040032
50 x 40	16	31	5	35	DIC050040
63 x 50	16	38	7	70	DIC063050
75 x 63	16	44	6	92	DIC075063
90 x 75	16	51	7	159	DIC090075
110 x 90	16	61	9	297	DIC110090

Fig. B

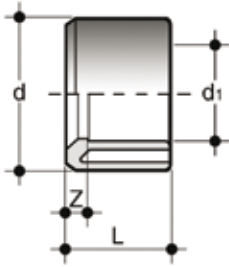

DIC

Reducing bush with solvent weld spigot (d) and solvent weld socket (d₁ reduced) (fig. B)

d x d ₁	PN	L	Z	g	Code
40 x 20	16	26	10	27	DIC040020
40 x 25	16	26	7	26	DIC040025
50 x 32	16	31	9	39	DIC050032
63 x 32	16	38	16	81	DIC063032
63 x 40	16	38	11.5	84	DIC063040
75 x 50	16	44	12	126	DIC075050
90 x 50	16	51	20	213	DIC090050
90 x 63	16	51	13	209	DIC090063
110 x 63	16	61	23	365	DIC110063
110 x 75	16	61	17	386	DIC110075
160 x 110	16	86	25	1040	DIC160110
225 x 160	10	119	33	2100	DIC225160

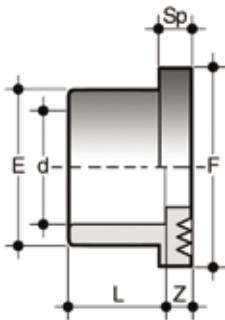

QRC

Stub with serrated face according to DIN 8063 PN 10/16 with solvent weld socket, for use with flat gasket (for gasket sizes, see QHV)

d	DN	PN	E	F	L	Sp	Z	g	Code
20	15	16	27	34	16	3.5	3.5	11	QRC020
25	20	16	33	41	19	3	3	17	QRC025
32	25	16	41	50	22	3	3	27	QRC032
40	32	16	50	61	26	3	3	43	QRC040
50	40	16	61	73	31	3	3	66	QRC050
63	50	16	76	90	38	3	3	116	QRC063
75	65	16	90	103	44	3	3	175	QRC075
90	80	16	108	125	51	5	5	305	QRC090
110	100	16	131	150	61	4	4	490	QRC110
160	150	16	188	212	86	4.5	5	1240	QRC160
225	200	10	245	273	119	25	6	1850	QRC225

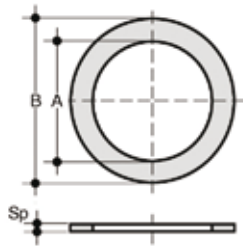

QHV/X

Flat gasket in EPDM and FPM for flanging system according to DIN 2501, EN 1092

d	DN	A	B	Sp	EPDM Code	FPM Code
20 - 1/2"	15	20	32	2	QHVX020E	QHVX020F
25 - 3/4"	20	24	38.5	2	QHVX025E	QHVX025F
32 - 1"	25	32	48	2	QHVX032E	QHVX032F
40 - 1" 1/4	32	40	59	2	QHVX040E	QHVX040F
50 - 1" 1/2	40	50	71	2	QHVX050E	QHVX050F
63 - 2"	50	63	88	2	QHVX063E	QHVX063F
75 - 2" 1/2	65	75	104	2	QHVX075E	QHVX075F
90 - 3"	80	90	123	2	QHVX090E	QHVX090F
110 - 4"	100	110	148	3	QHVX110E	QHVX110F
125	125	125	166	3	QHVX125E	QHVX125F
140	125	140	186	3	QHVX140E	QHVX140F
160 - 6"	150	160	211	3	QHVX160E	QHVX160F
200	200	200	252	4	QHVX200E	-
225 - 8"	200	225	270	4	QHVX225E	-

Note: for flat gaskets QHV/X d 250 see PVC-U Fittings Catalogue

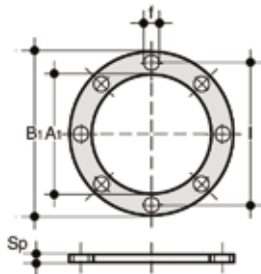

QHV/Y

Flat gasket in EPDM for flanging system according to DIN 2501, EN 1092, self-centring for flanges drilled PN 10/16 up to DN 150 and PN 10 from DN 200

d	DN	A ₁	B ₁	f	l	U	Sp	Code
20 - 1/2"	15	17	95	14	65	4	2	QHVY020E
25 - 3/4"	20	22	107	14	76.3	4	2	QHVY025E
32 - 1"	25	28	117	14	86.5	4	2	QHVY032E
40 - 1" 1/4	32	36	142.5	18	101	4	2	QHVY040E
50 - 1" 1/2	40	45	153.3	18	111	4	2	QHVY050E
63 - 2"	50	57	168	18	125.5	4	2	QHVY063E
75 - 2" 1/2	65	71	187.5	18	145.5	4	3	QHVY075E
90 - 3"	80	84	203	18	160	8	3	QHVY090E
110 - 4"	100	102	223	18	181	8	3	QHVY110E
125	125	132	250	18	210	8	3	QHVY125E
140	125	132	250	18	210	8	3	QHVY140E
160 - 6"	150	152	288.5	22	241.5	8	4	QHVY160E
200	200	192	340	22	295	8	4	QHVY200E
225 - 8"	200	215	340	22	295	8	4	QHVY225E

Note: for flat gaskets QHV/Y from d250 to d400, see PVC-U Fittings Catalogue

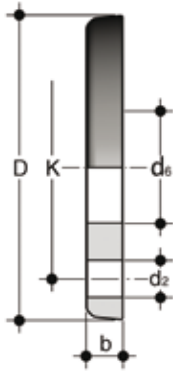

ODC

Backing ring in PVC-C for stubs QRC EN/ISO/DIN.
Drilling: PN10 up to DN100

d	DN	*PMA (bar)	b	d ₂	d ₆	D	K	M	n	**(Nm)	g	Code
20	15	10	11	14	28	96	65	M12x70	4	10	66	ODC020
25	20	10	12	14	34	107	75	M12x70	4	10	93	ODC025
32	25	10	14	14	42	116	85	M12x70	4	10	122	ODC032
40	32	10	15	18	51	142	100	M16x85	4	13	200	ODC040
50	40	10	16	18	62	153	110	M16x85	4	13	245	ODC050
63	50	10	18	18	78	168	125	M16x95	4	15	310	ODC063
75	65	10	19	18	91	188	145	M16x95	4	17	425	ODC075
90	80	10	20	18	109	199	160	M16x105	8	18	455	ODC090
110	100	10	22	18	132	219	180	M16x105	8	20	545	ODC110

*PMA maximum admissible working pressure
**(Nm) nominal tightening torque

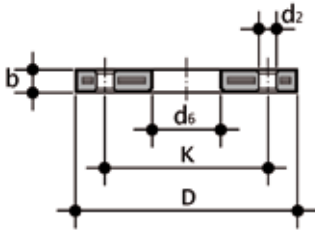

ODB

Steel core backing ring, PP/FRP coated, according to EN/ISO/DIN for stubs QRC
Drilled PN 10/16 up to DN 150

d	DN	*PMA (bar)	b	d ₂	d ₆	D	k	M	n	**(Nm)	g	Code
20	15	16	12	14	28	95	65	M12	4	15	290	ODB020
25	20	16	14	14	34	105	75	M12	4	15	410	ODB025
32	25	16	14	14	42	115	85	M12	4	15	610	ODB032
40	32	16	16	18	51	140	100	M16	4	20	880	ODB040
50	40	16	16	18	62	150	110	M16	4	30	810	ODB050
63	50	16	19	18	78	165	125	M16	4	35	940	ODB063
75	65	16	19	18	92	185	145	M16	4	40	1210	ODB075
90	80	16	21	18	109	200	160	M16	8	40	1480	ODB090
***125	100	16	22	18	134	220	180	M16	8	40	1570	ODB125
****180	150	16	27	22	191	285	240	M20	8	60	3470	ODB180

*maximum admissible pressure values according to EN/ISO/DIN.
** nominal tightening torque
*** for use with stubs QRC110
**** for use with stubs QRC160

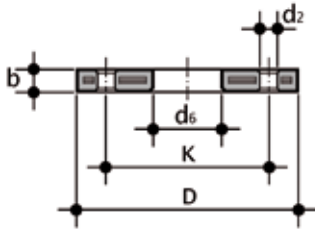

ODB-SW

Steel core backing ring, PP/FRP coated, according to EN/ISO/DIN for stubs QRC

d	DN	*PMA (bar)	b	d ₂	d ₆	D	k	M	n	** (Nm)	g	Code
225	200	16	27	22	247	340	295	M20	8	75	5060	SWOBD225DN200

*PMA maximum admissible working pressure
**nominal tightening torque

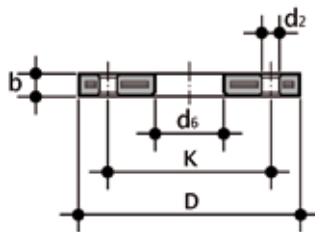

OAB

Steel core backing ring, PP/FRP coated according to ANSI B16.5 cl.150 for stubs QRC

d	DN	*PMA (bar)	b	mm d ₂	inch d ₂	d ₆	D	mm K	inch K	n	** (Nm)	g	Code
1/2"	15	16	12	16	5/8"	28	95	60.45	2"3/8	4	15	220	OAB012
3/4"	20	16	12	16	5/8"	34	102	69.85	2"3/4	4	15	240	OAB034
1"	25	16	16	16	5/8"	42	114	79.25	3"1/8	4	15	390	OAB100
1"1/4	32	16	16	16	5/8"	51	130	88.9	3"1/2	4	25	510	OAB114
1"1/2	40	16	18	16	5/8"	62	133	98.55	3"7/8	4	35	580	OAB112
2"	50	16	18	20	3/4"	78	162	120.65	4"3/4	4	35	860	OAB200
2"1/2	65	16	18	20	3/4"	92	184	139.7	5"1/2	4	40	1100	OAB212
3"	80	16	18	20	3/4"	111	194	152.4	6"	4	40	1040	OAB300
4"	100	16	18	20	3/4"	133	229	190.5	7"1/2	8	40	1620	OAB400

*PMA maximum admissible working pressure
**nominal tightening torque

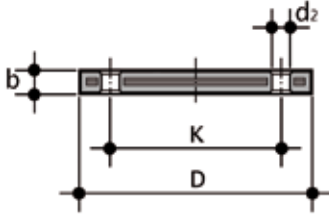

ODBC

Steel core blind flange, PP/FRP coated, according to EN/ISO/DIN Drilling: PN 10/16

d	DN	*PMA (bar)	b	d ₂	D	k	M	n	** (Nm)	g	Code
20	15	16	12	14	95	65	M12	4	15	290	ODBC020
25	20	16	12	14	105	75	M12	4	15	390	ODBC025
32	25	16	16	14	115	85	M12	4	15	550	ODBC032
40	32	16	16	18	140	100	M16	4	25	820	ODBC040
50	40	16	16	18	150	110	M16	4	35	900	ODBC050
63	50	16	16	18	165	125	M16	4	35	1150	ODBC063
75	65	16	18	18	185	145	M16	4	40	1680	ODBC075
90	80	16	18	18	200	160	M16	8	40	2240	ODBC090
110/125	100	16	20	18	220	180	M16	8	40	2800	ODBC110
160/180	150	16	24	22	285	240	M20	8	60	5080	ODBC160

*PMA maximum admissible working pressure
 **nominal tightening torque

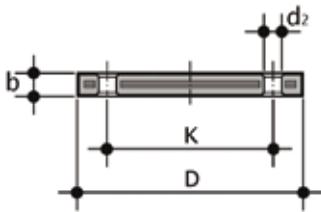

OABC

Steel core blind flange, PP/FRP coated according to ANSI B16.5 cl.150

d	DN	*PMA (bar)	b	mm d ₂	inch d ₂	D	mm K	inch K	n	** (Nm)	g	Code
1/2"	15	16	12	16	5/8"	95	60.45	2"3/8	4	15	200	OABC012
3/4"	20	16	12	16	5/8"	102	69.85	2"3/4	4	15	240	OABC034
1"	25	16	16	16	5/8"	114	79.25	3"1/8	4	15	370	OABC100
1"1/4	32	16	16	16	5/8"	130	88.90	3"1/2	4	25	530	OABC114
1"1/2	40	16	18	16	5/8"	133	98.55	3"7/8	4	35	560	OABC112
2"	50	16	18	20	3/4"	162	120.65	4"3/4	4	35	810	OABC200
2"1/2	65	16	18	20	3/4"	184	139.70	5"1/2	4	40	1070	OABC212
3"	80	16	18	20	3/4"	194	152.40	6"	4	40	1030	OABC300
4"	100	16	18	20	3/4"	229	190.50	7"1/2	8	40	1570	OABC400

*PMA maximum admissible working pressure
 **nominal tightening torque